

ND-VFC500 VFFS PACKAGING MACHINE

AFFORDABLE
AND HIGH
EFFECTIVE

Max
2400
Bags/Hour



PRODUCT DESCRIPTION

Model ND-VFC500 packaging machine specially for packaging products into big bags. Max bag range is 50L. Suitable for various granule, powder products.

Simple, safe operation, reliable stable running, strong practicability, high economic benefit.

NEWIDEA PACK

Flexible Packaging Machinery Manufacturer

ND-VFC500 VFFS PACKAGING MACHINE

BAG TYPE

Bag type: Pillow bag, gusseted bag, corner creased bag, flat bottom bag, one way exhaust valve can be added.

Packaging materials: Aluminized film, paper-plastic composite film and other laminated film.



Pillow Bag



Gusseted Bag



Corner Creased Bag



Flat Bottom Bag



Bag With Valve



Bag With Finger Grip



Continuous Bag

APPLICATION

Model ND-VFC500 can pack from 3kg-20kg, which normal are large wholesale package for daily supplies consumables, factory raw materials, restaurant raw materials etc. Like frozen food, rice, beans, seeds, grains, ice cubes, sugar, salt, flour, starch, washing powder etc, barbecue charcoal and so on. The big package it's more convenient for stock.



ND-VFC500 VFFS PACKAGING MACHINE

PRODUCT FEATURE

- Multi-language colorful HMI interaction interface, intuitive and simple operation.
- Adopt Japanese Mitsubishi or France Schneider PLC control system, can store 10 kinds of product parameters, and adjust parameters without stopping the machine.
- The film feeding mechanism is equipped with a brake motor, an inflatable shaft, and the film tension is uniform, which is convenient and quick to change the film. The film is pulled using a Schneider servo phone to ensure mechanical stability.
- Intelligent detection, correction detection (correction motor, touch screen operation), length detection (cursor, encoder), the error range is $\pm 1\text{mm}$.
- The temperature control system adopts the Japanese Omron temperature control meter, and the horizontal and vertical sealing are independent temperature control; the sealing system adopts SMC cylinder, which is suitable for various Laminated films and PE films, and the packaging is beautiful and firm.
- No film, no material, no ribbon, automatic alarm, open door and shutdown alarm, failure alarm.
- Low failure rate, high efficiency and stability, safe production for more than 10 years.
- Machine welding structure is open, convenient for maintenance and cleaning.
- Basic associated equipment, makes the machine give full play to its advantages. Realize automatic lifting, weighing, filling, bag making, sealing, cutting.

PARAMETER

Model	ND-VFC500
Bag width	200-500mm
Bag length	300-950mm
Max speed	40 bags/minute
Max width of roll film	1050mm
Filling range	20L
Air pressure	0.8mpa
Air consumption	0.6m ³ /min
Voltage power	220V/380V, 50-60HZ, 5Kw
Machine weight	1200Kgs
Package dimension	1843x2516x2892mm (L*W*H)

OUTLINE DIAGRAM

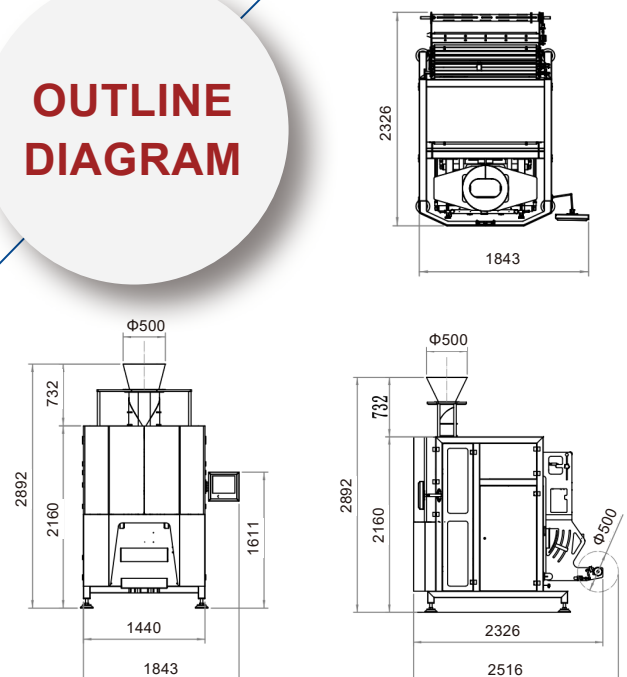

ND-VFC500 VFFS PACKAGING MACHINE

OPTIONAL ACCESSORIES

POWDER PACKAGING SOLUTION



- Screw Elevator



- Auger Feeder



- Host Machine



- Rotating Table



- Finished Product Conveyor

GRANULES PACKAGING SOLUTION



- Z-Shape Elevator



- Multihead Scale



- Platform



- Host Machine



- Finished Product Conveyor

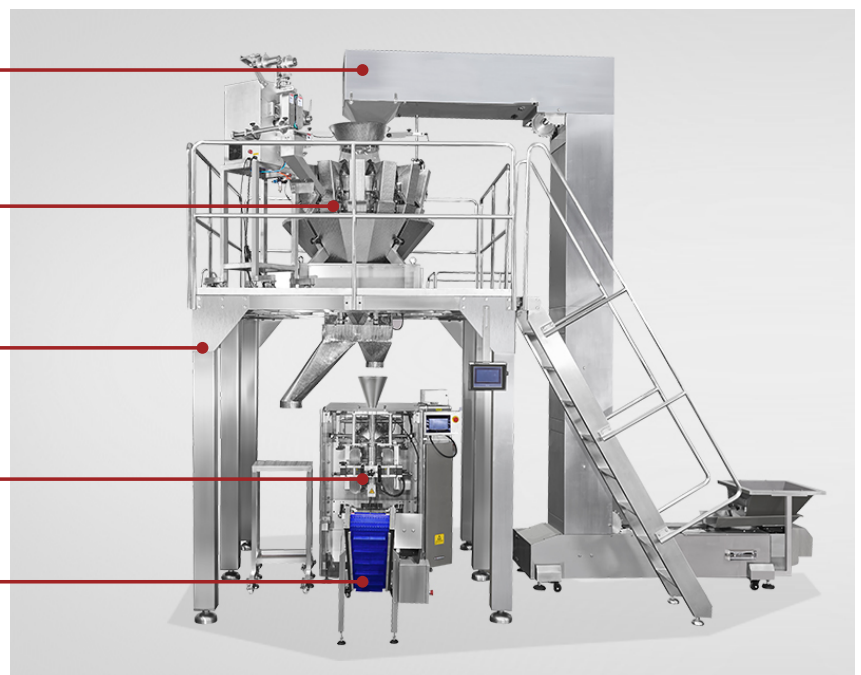

ND-VFC500 VFFS PACKAGING MACHINE

OPTIONAL ACCESSORIES

OTHER OPTIONS



Metal Detector



Weight Checker



CONTACT US

- +86-13920157717
- www.newideapack.com
- autopacking@newideabest.com
- No.9 Sanxing Road, Xiqing District, Tianjin , China.

NEWIDEA PACK

Flexible Packaging Machinery Manufacturer