

# ND-VFC350 VFFS PACKAGING MACHINE

AFFORDABLE  
AND HIGH  
EFFECTIVE

Max  
**3000**  
Bags/Hour



## PRODUCT DESCRIPTION

Model ND-VFC350 packaging machine is for packaging 1-8kg granular ,powder,paste, liquid products for food,health care products, pharmaceuticals,chemical, hardware and other industries. Designed with the resource saving, safety, freshness preservation, highest efficient and waste reduction as their important features.

**NEWIDEA PACK**

Flexible Packaging Machinery Manufacturer

# ND-VFC350 VFFS PACKAGING MACHINE

## BAG TYPE

**Bag type:** Pillow bag, gusseted bag, corner creased bag, flat bottom bag, one way exhaust valve can be added.

**Packaging materials:** Aluminized film, paper-plastic composite film and other laminated film.



Pillow Bag



Gusseted Bag



Corner Creased Bag



Flat Bottom Bag

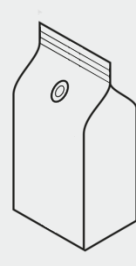

Bag With Valve



Bag With Finger Grip



Continuous Bag

## APPLICATION

**Granules:** Snacks, cereals, frozen products, pet food, veterinary medicine, chemicals, hardware etc.

**Powder:** Milk powder, flour, grain powder, starch, seasoning powder, protein powder, vegetable powder, fruit powder, coffee powder, medicine powder, etc.

**Paste and liquid:** Tomato sauce, fruit jam, honey, salad dressing, putty paste oil, fruit juice, etc.



# ND-VFC350 VFFS PACKAGING MACHINE

## PRODUCT FEATURE

- Multi-language colorful HMI interaction interface, intuitive and simple operation.
- Adopt Japanese Mitsubishi or France Schneider PLC control system, can store 10 kinds of product parameters, and adjust parameters without stopping the machine.
- The film feeding mechanism is equipped with a brake motor, an inflatable shaft, and the film tension is uniform, which is convenient and quick to change the film. The film is pulled using a Schneider servo phone to ensure mechanical stability.
- Intelligent detection, correction detection (correction motor, touch screen operation), length detection (cursor, encoder), the error range is  $\pm 1$ mm.
- The temperature control system adopts the Japanese Omron temperature control meter, and the horizontal and vertical sealing are independent temperature control; the sealing system adopts SMC cylinder, which is suitable for various Laminated films and PE films, and the packaging is beautiful and firm.
- No film, no material, no ribbon, automatic alarm, open door and shutdown alarm, failure alarm.
- Low failure rate, high efficiency and stability, safe production for more than 10 years.
- Machine welding structure is open , convenient for maintenance and cleaning.
- Basic associated equipment,makes the machine give full play to its advantages.Realize automatic lifting,weighing, filling, bag making,sealing, cutting.

## PARAMETER

Model	ND-VFC350
Bag width	150-350mm
Bag length	100-500mm
Max speed	50 bags/minute
Max width of roll film	720mm
Filling range	5000ml(Max)
Air pressure	0.65mpa
Air consumption	0.6m <sup>3</sup> /min
Voltage power	220V/380V,50-60HZ, 5Kw
Machine weight	700Kgs
Package dimension	1320x1700x1810mm (L*W*H)

## OUTLINE DIAGRAM

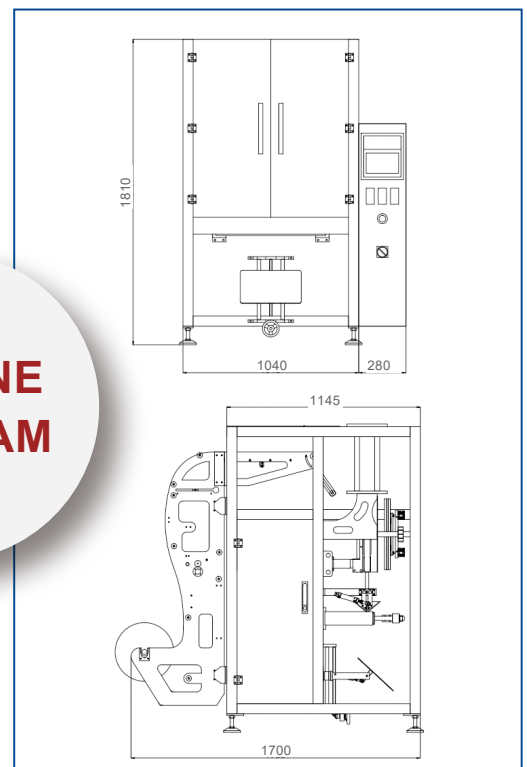





# ND-VFC350 VFFS PACKAGING MACHINE

## OPTIONAL ACCESSORIES





### POWDER PACKAGING SOLUTION

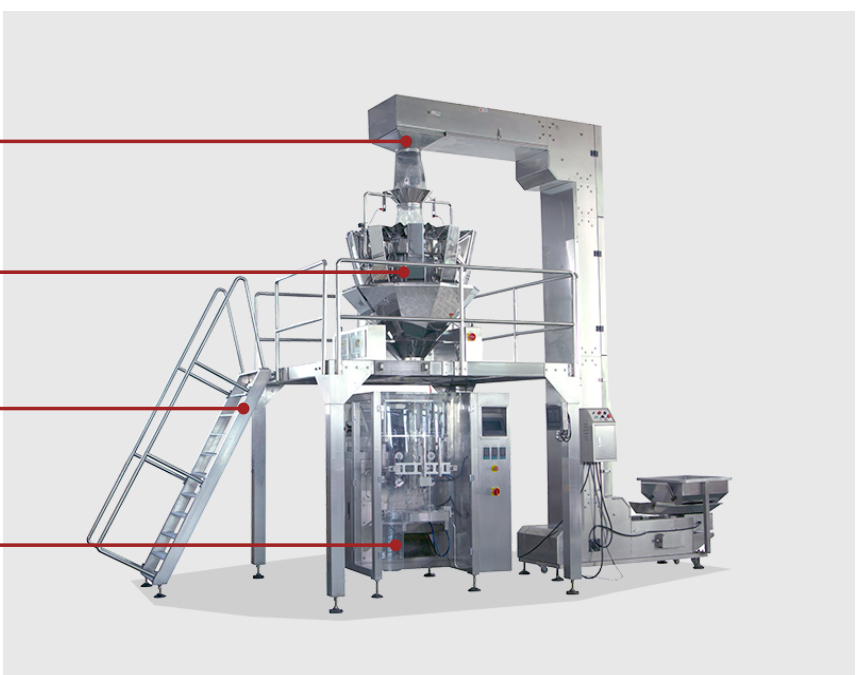

-  Screw Elevator
-  Auger Feeder
-  Host Machine
-  Rotating Table
-  Finished Product Conveyor

### GRANULES PACKAGING SOLUTION



-  Z-Shape Elevator
-  Multihead Scale
-  Platform
-  Host Machine

# ND-VFC350 VFFS PACKAGING MACHINE

## OPTIONAL ACCESSORIES

### ● PASTE AND LIQUID PACKAGING SOLUTION

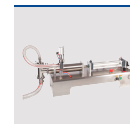
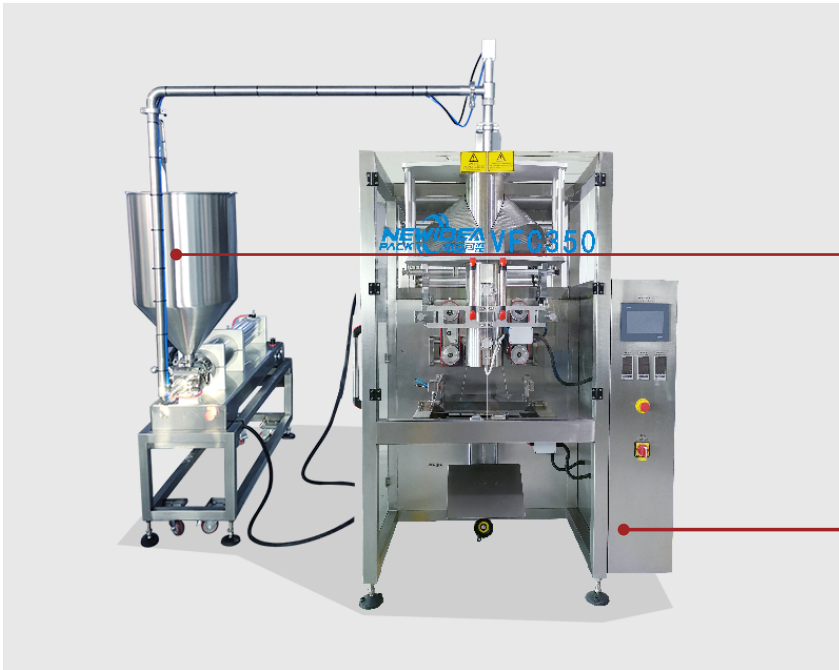

- Liquid Pump



- Paste Pump



- Rotor Pump



- Host Machine

### OTHER OPTIONS



Metal Detector



Weight Checker



## CONTACT US

- ☎ +86-13920157717
- 🌐 [www.newideapack.com](http://www.newideapack.com)
- ✉ [autopacking@newideabest.com](mailto:autopacking@newideabest.com)
- 📍 No.9 Sanxing Road, Xiqing District, Tianjin , China.

**NEWIDEA PACK**

Flexible Packaging Machinery Manufacturer